

Overview

The Mercury CA1 module offers high-performance yet low cost Altera Cyclone IV FPGAs in conjunction with standard interfaces like USB 2.0 and Gigabit Ethernet.

With its powerful FPGA and standard interfaces, the many LVDS capable I/Os, the large DDR2 SDRAM and the many hardware multipliers it is equally suited for digital signal processing, networking, high-speed I/O as well as SoPC applications utilizing the Altera Nios II soft processor.

The Mercury CA1 FPGA module reduces development effort, redesign risk and improves time-to-market.

Benefits

- Vast parallel processing power for DSP applications (up to 200 multipliers at 260 MHz = 52 GMAC/s)
- High-bandwidth data I/O thanks to the large number of available LVDS pairs
- Simple and low-cost integration thanks to standard interfaces (USB, Gigabit Ethernet), single supply voltage and 2.5V / 3.3V power outputs
- Big and high-bandwidth data memory thanks to DDR2 SDRAM
- Many IP cores are available from Altera, Enclustra and 3rd parties.
- Simplified carrier board design (typically 4 layers)

Highlights

- Features the latest Altera low-cost FPGA family
- Provides a FTDI-based USB 2.0 High-Speed interface
- Provides a Gigabit Ethernet PHY for high-bandwidth/low-latency networking
- Smaller than a credit-card
- Requires only a single supply voltage (5..16V)

Features

- Altera Cyclone IV E FPGA in the 484-pin FBGA package
- Small form factor (56 x 54 mm, dual 168-pin Hirose FX10 connectors)
- 25 differential pairs and 98 single-ended user I/Os or 146 single-ended user I/Os (168 with custom configuration)
- Up to 16 MB SPI Flash
- Up to 256 MB (64Mx16) DDR2 SDRAM
- FTDI USB 2.0 High-Speed interface
- Gigabit Ethernet PHY
- High-power 8A core power supply

Module Architecture

Mercury CA1 FPGA Module

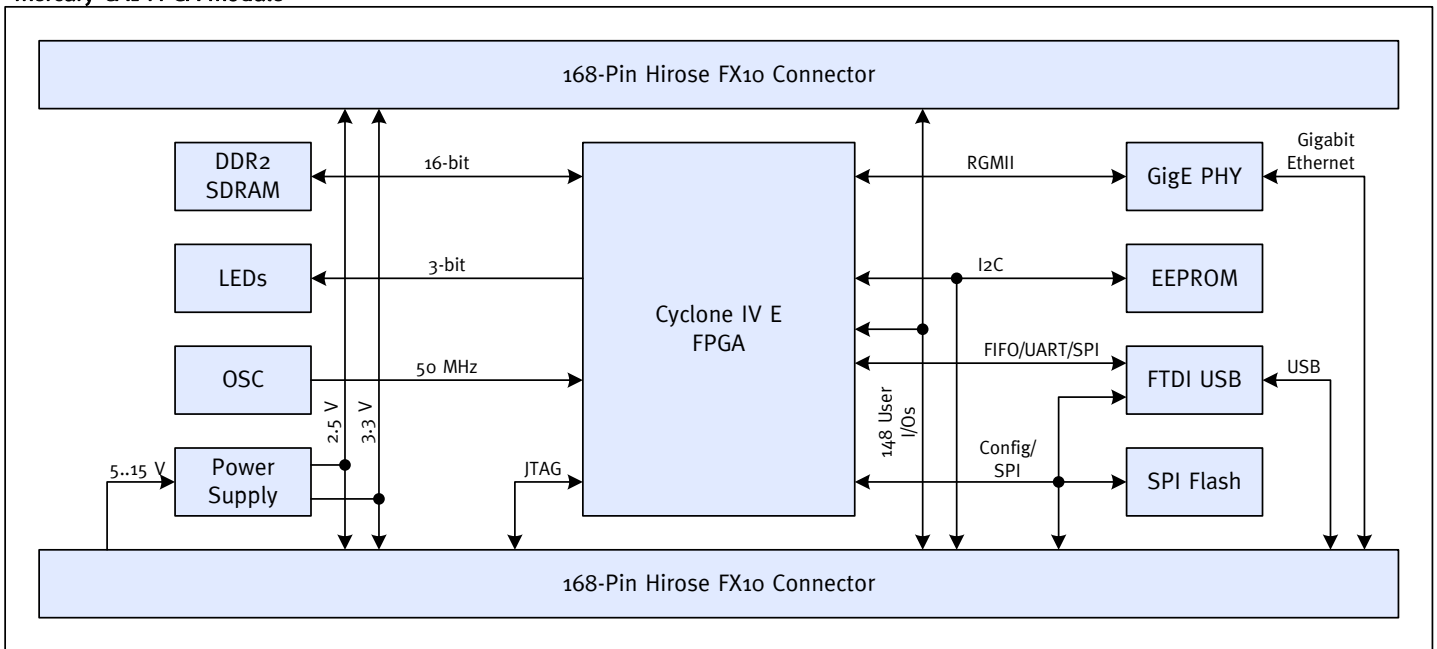

Product Selection Matrix

Product Number	FPGA	SPI FLASH	DDR2 SDRAM	Gigabit Ethernet	USB 2.0	Temp. Range
ME-CA1-30-C8	EP4CE30F23C8N	16 MB	128 MB	✓	✓	0..+70°C
ME-CA1-75-C8	EP4CE75F23C8N	16 MB	128 MB	✓	✓	0..+70°C
Custom Configurations	EP4CE 30 F23 C 6 N 40 I 7 LN 55 8 75 115	✗ 8 MB 16 MB	✗ 128 MB 256 MB	✗ ✓	✗ ✓	0..+70°C -40..+85°C

Minimum order quantities may apply for custom module configurations. Please contact us.

Target Applications

- Digital Signal Processing
- Video Processing
- Audio Processing
- Motion Control
- Software Defined Radio
- Communications
- Embedded Computing
- Networking

Related Products

- Enclustra Mercury Starter Base Board
- Enclustra Avalon FTDI Controller IP Core
- Enclustra TFT Display Controller IP Core
- Enclustra Universal Drive IP Core