



# Product Brief

## Mars MX2

### Spartan-6 LXT FPGA Module



## Overview

The Mars MX2 FPGA module is equipped with PCI-Express-capable multi-gigabit serial transceivers, Gigabit Ethernet and DDR2 SDRAM and is thus perfectly suited for high speed communication and DSP applications.

The SO-DIMM form factor allows space-saving hardware designs as well as quick and simple integration of the module into the target application.

The Mars MX2 FPGA module reduces development effort, redesign risk and improves time-to-market.

## Highlights

- Low-cost, low-power FPGA
- Dual multi-gigabit transceivers
- Comes in the handy SO-DIMM form factor
- Available in the industrial temperature range
- Supports PCI-Express and Gigabit Ethernet

## Benefits

- Simple, low cost and yet rugged assembly thanks to the industry-standard SO-DIMM form factor
- Simple and low-cost integration thanks to the on-board standard interfaces (PCIe, Ethernet)
- Fast boot times and support for execution-in-place (XiP) thanks to the 4 bit parallel SPI Flash
- High-bandwidth program and data memory thanks to the high-performance hard-macro memory controller
- Lowest power consumption thanks to the high-efficiency DC/DC converters and support for SUSPEND.
- Many IP cores are available from Xilinx, Enclustra and 3rd parties.

## Features

- Xilinx Spartan-6 LXT FPGA in the CSG324 package (XC6SLX45T as standard option)
- SO-DIMM form factor (68 x 30 mm, 200 pins)
- 2 GTP Gigabit Transceivers (3.125 Gb/s)
- 96 user I/Os, single-ended or differential
- Up to 16 MB quad SPI Flash
- Up to 256 MB DDR2 SDRAM
- Gigabit Ethernet PHY
- PCIe Endpoint
- Single 3.3V supply voltage



## Module Architecture

### Mars MX2 FPGA Module

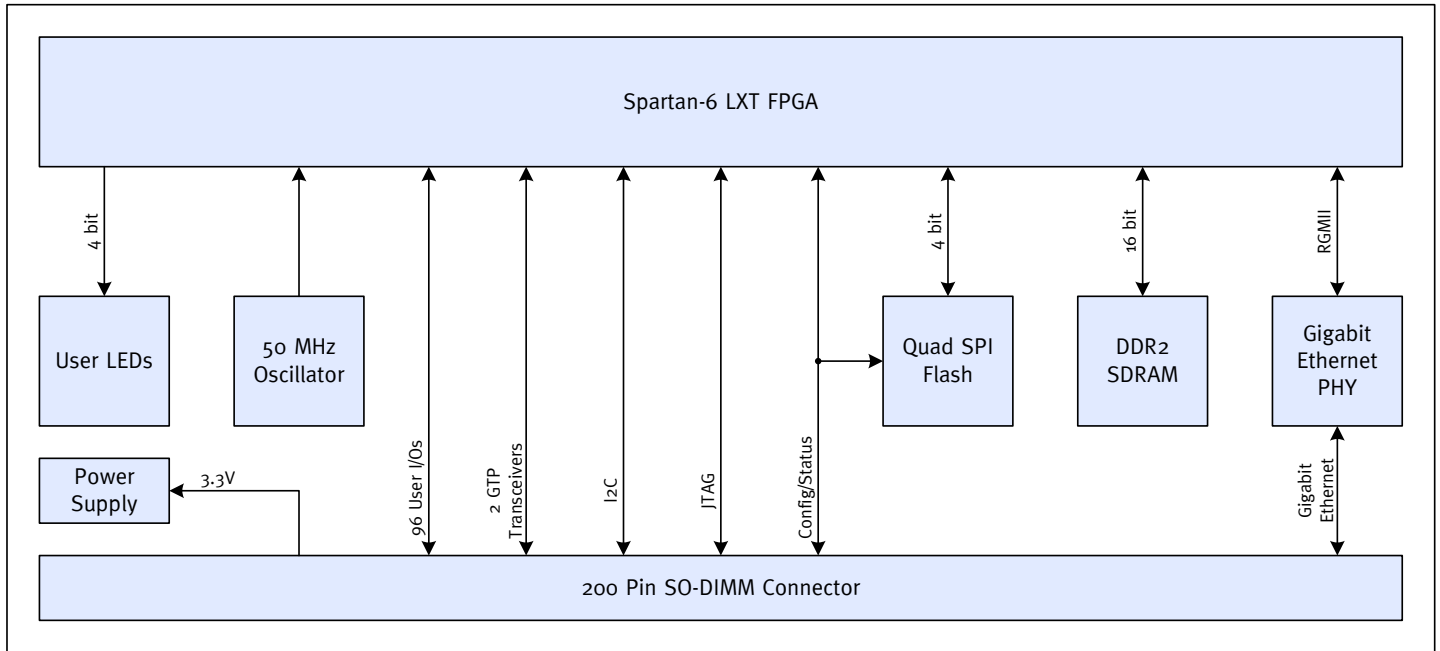

## Product Selection Matrix

Product Number	FPGA	Quad SPI FLASH	DDR2 SDRAM	Ethernet PHY	Real Time Clock	Temp. Range
MA-MX2-45-3C	XC6SLX45T-3CSG324C	16 MB	128 MB	1 Gbps	✓	0..+70°C
Custom Configurations	XC6SLX 25 T- 2 CSG324 C 45 3 1 4	✗ 4 MB 8 MB 16 MB	✗ 64 MB 128 MB 256 MB	✗ 1 Gbps	✗ ✓	0..+70°C -40..+85°C

Minimum order quantities may apply for custom module configurations. Please contact us.

## Target Applications

- PCIe Endpoint
- Data Acquisition
- High-Speed Communications
- Digital Signal Processing
- Image Processing
- Embedded Computing

## Related Products

- Enclustra Mars Starter Base Board
- Enclustra FMC Drive Evaluation Board
- Enclustra Universal Drive Controller IP Core
- Enclustra Advanced Velocity Estimator IP Core